

THE BEAST

HITCH CARRIER

Giving our customer the ability to configure heights to maximize the functionality of our hitch carrier is our goal. We've designed our carrier to achieve the strength of a 'full load' carrier and the flexibility to give the user the best functional options for carrying and general usage possible. **The BEAST** is the premier carrier on the market!

With an impressive **800-pound distributed load** in the 'flat' position (600-pound on the edges) ... it can be used to carry the most difficult loads – Securely and Safely! Look at the load and functional options of **The BEAST**!

SECURE • DURABLE • COST EFFECTIVE

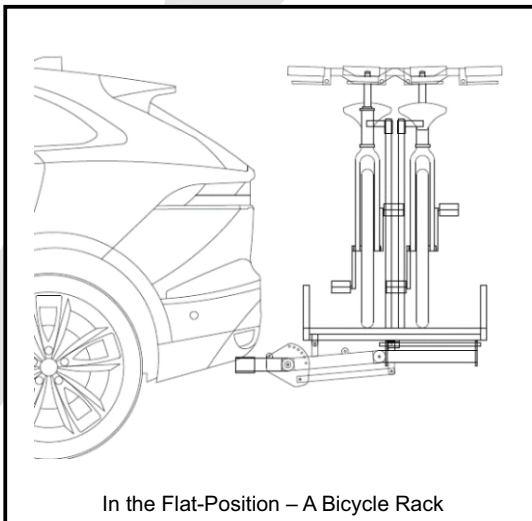

In the Flat-Position – A Bicycle Rack

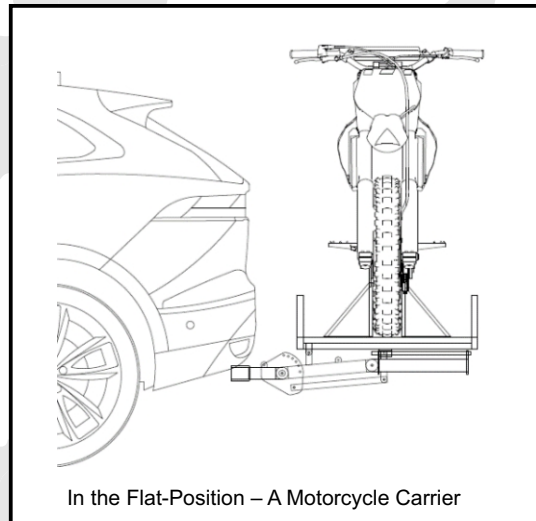

In the Flat-Position – A Motorcycle Carrier

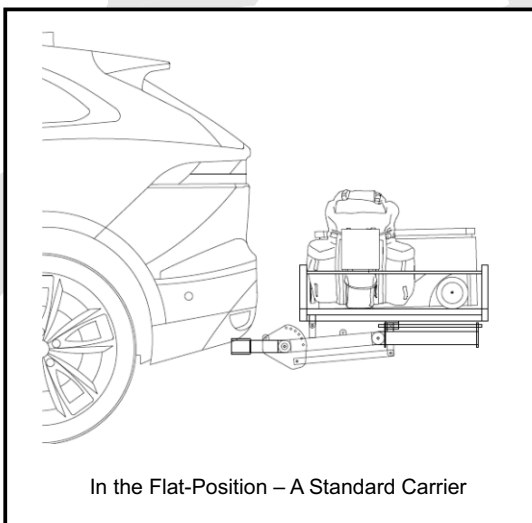

In the Flat-Position – A Standard Carrier

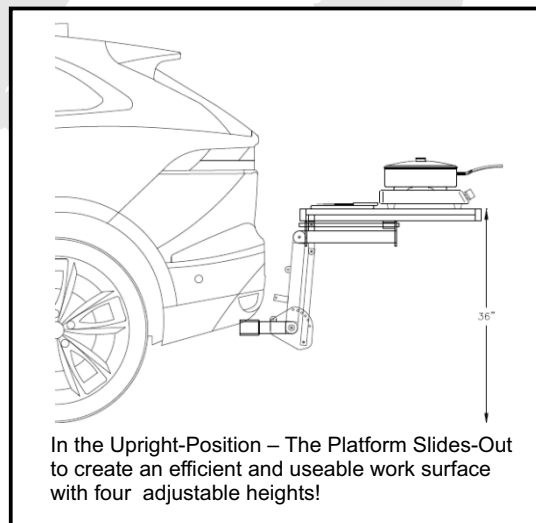

In the Upright-Position – The Platform Slides-Out to create an efficient and useable work surface with four adjustable heights!



PROUDLY CANADIAN



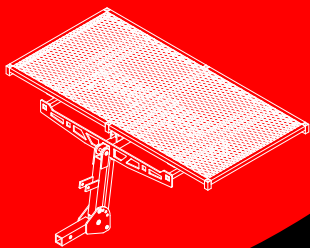

THE BEAST

HITCH CARRIER

And, there's MORE! With **ONE SIMPLE PIN** change, you can adjust the height of the carrier to meet your needs! The platform will **ALWAYS stay level** for any use you can imagine! The Adjustable Height and Sliding Platform allow for a multitude of use features.

Multi-Use Carrier can be used for ...

- Bike Carrier
- Camp Site table
- Work Surface
- Play Table
- Cook Top
- Hazardous Fluid hauler
- Use your imagination!

Included in ALL platforms:

- Bicycle posts - removable and lockable in place for secure transportation of your bike.
- Side Rails removable for a Ramp to move heavier items onto the platform.

With a 800 pound (365kg) distributed load capacity ... The BEAST is in a class by itself! Imagine the possibilities!

PRODUCT SPECIFICATIONS:

Hitch Mount:	Ruggedized 2" mount made from 8 Gauge, square tube.
Frame Material:	10 Gauge, Cold-Rolled, High-Grade Steel
Mesh Material:	12 Gauge, Expanded Mesh, welded wire mesh for the platform.
Fasteners:	All components are SAE Certified for Strength, Durability and Performance
Coating:	Powdered Polyester Resin with UV and Maximum Rust Protection
Weldments:	All weldments meet or exceed the CWB standards for medium-gauge material welding of components which ensures exceptional performance and durability
Dimension:	30" x 60" (762mm x 1,524mm)
NET Weight:	95 Pounds (without Side Rails) (43kg empty)
Installation:	All installation ... just plug into your receiver, push in the safety pin and lock it in place ... and you're DONE!
SPECIAL FEATURE:	The Side Rails also double as a RAMP to load and of f-load heavy toys (motorcycle, quad's scooters, etc.) or construction equipment!

For more information on any of our products, please give us a call. We'd be happy to assist you in finding the best solution for your needs.

Backed by our 2-Year Limited Warranty!

Wire Guard Solutions Inc.
WG Consumer Products Division
14 Bram Court
Brampton, Ontario L3W 6R3
Phone 905-475-0688
Email: tim@wireguardsolutions.ca

WIRE GUARD
SOLUTIONS